

SS-Unfold™

As our industry embraces engineering systems such as SolidWorks®, Autodesk Inventor®, and Solid Edge®, STRIKER CAD/CAM takes full advantage of the unfolding capability provided with these solutions. For organizations without solid modeling technology Striker Systems offers SS-Unfold, an advanced 3-D and 2-D unfolding system for wireframe part models. Its extensive feature set allows you to effortlessly create accurate flat parts in seconds.

- 3-D & 2-D Wireframe Unfolding
- User Defined Bend Calculations
- Incorporates Historical Bend Data
- User Materials Library
- Spring-Back Calculator
- 3-D Folding
- Complex Corner Joint Development
- Auto Bend Chart Creation
- Bend Calculation Override
- 2-D Progressive Unfolding
- Bend Design Features
- Part Integrity Verification
- Share Bend Data w/ Other STRIKER CAD/CAM Applications

Three Dimensional Unfolding

SS-Unfold is the most full featured unfolding system available today for flat blank development from 3-D wire-frame models. All unfolding is based on a user defined material type, bend radius and unfolding calculation method.

Models can be created with either straight line or arc bend representations. Material thickness can be represented or a single surface wire-frame drawing can be used. The model can be unfolded around any desired part plane.

The flat blank is precisely created. Bend lines are created on a separate layer for easy display control. And each bend line is assigned its specific bending data for creation of a bending table.

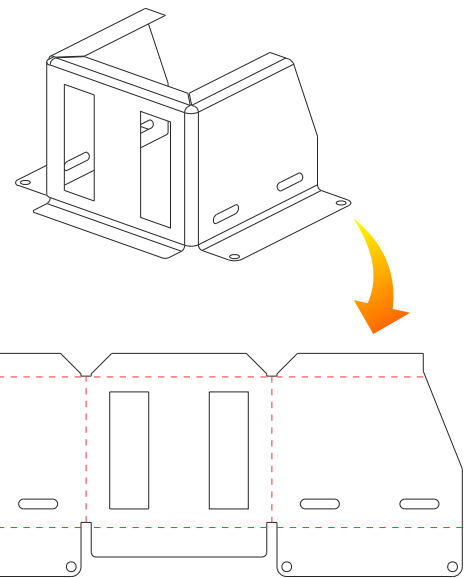

Two Dimensional Unfolding

SS-Unfold includes 2-D unfolding from a standard orthographic drawing. 2-D sections are unfolded to flat blank profile. As the formed profile is straightened, all appropriate bend allowances are accurately calculated and reflected in the updated geometry.

Any geometry in the drawing can be associated to any segment of the 2-D profile during the unfolding process. This allows holes, notches, or any other part feature to be carried through the unfolding process and properly positioned for flat blank development.

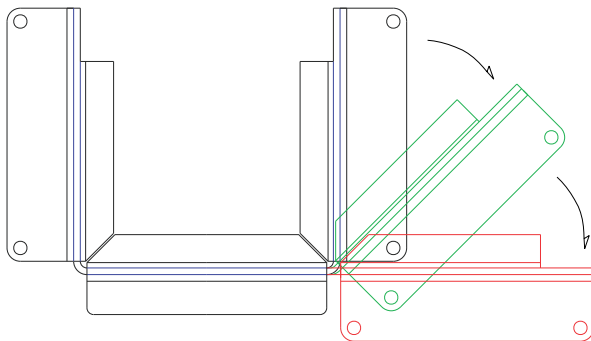

**Continued on next page.*

Automatic Bend Charts

All bending data is stored with each bend in the unfolded part. This includes a bend reference number (with corresponding reference balloon on the bend), bend allowance, neutral axis, bend radius, form radius, bend angle, over-bend angle, and bend direction. All bending data can be sent directly to a printer, saved in a text file, or a bend table can be positioned in the drawing.

BEND LINE DATA TABLE							
Name : 3D							
Material : A.I.S.I. 1020 Annealed Mild Steel							
Thickness: 0.1250							
Bend Number	Bend Allowance	Neutral Axis	Bend Radius	Form Radius	Bend Angle	Springback Angle	Bend Direction
1	0.2618	33.33	0.1250	0.1138	90.00	95.74	UP
2	0.2618	33.33	0.1250	0.1138	90.00	95.74	UP
3	0.2618	33.33	0.1250	0.1138	90.00	95.74	DOWN
4	0.2618	33.33	0.1250	0.1138	90.00	95.74	DOWN
5	0.2618	33.33	0.1250	0.1138	90.00	95.74	DOWN
6	0.4581	33.33	0.2500	0.2188	90.00	100.00	UP
7	0.4581	33.33	0.2500	0.2188	90.00	100.00	UP
8	0.4581	33.33	0.2500	0.2188	90.00	100.00	UP

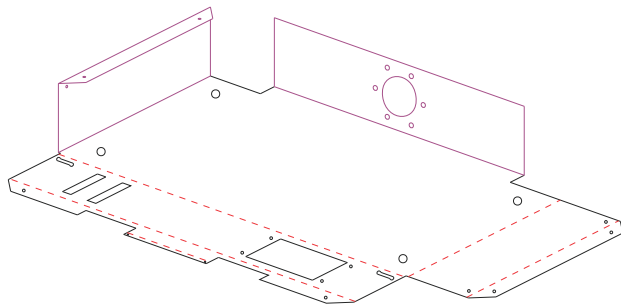

Three Dimensional Folding

SS-Unfold also includes the ability to fold 2-D flat parts into 3-D wire-frame models. Perfect for verifying original designs and engineering changes. Simply draw bend lines at the desired locations, or use the existing bend lines if the part was previously unfolded with SS-Unfold. Assign the desired bend data and construct a 3-D model.

Corner Joint Development

A unique feature of SS-Unfold is the ability to develop a corner joint on any inclusive angle from a standard 2-D orthographic drawing. Simply unfold the part profile and select the object in the plan view that represents the joining corner. The complex corner geometry is automatically created.

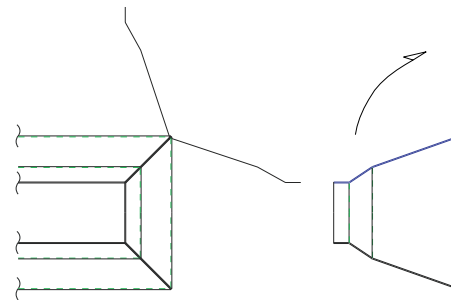

Materials Library

The basis of all unfolding operations is an advanced materials library that allows the design engineer to control the outcome to match known data. Along with material properties including shear, yield and tensile strengths, the neutral axis of each material can be varied with changes in the bend radius and/or material thickness. This allows the bend allowance calculated to be more accurate based on material thickness and the radius of a specific bend.

Also assigned to each material is a spring-back chart. By assigning the known data of a specific material to the chart, you can have SS-Unfold tell you the over-bend angle required for each bend.

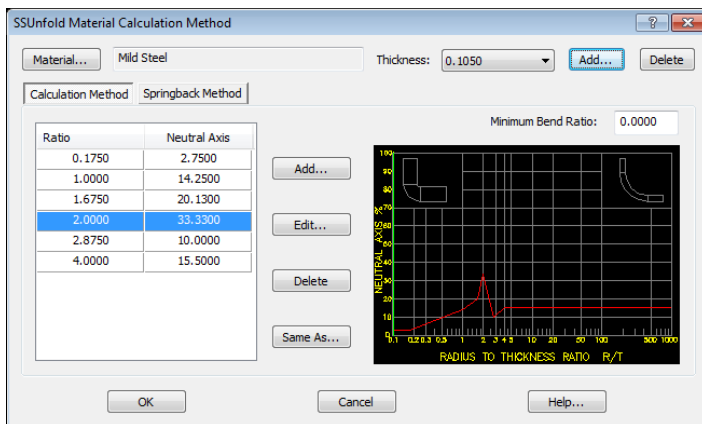

*Continued on next page.

System Requirements

Supported operating systems

32-bit & 64-bit

- Microsoft® Windows® 10
- Microsoft® Windows® 8/8.1 Professional and Enterprise
- Microsoft® Windows® 7 Professional, Ultimate, and Enterprise

• Supported CPU type

32-bit

- 32-bit Intel® Pentium® 4 or AMD Athlon™ Dual Core, 3.0 GHz or higher with SSE2 technology

64-bit

- AMD Athlon 64 with SSE2 technology
- AMD Opteron™ with SSE2 technology
- Intel® Xeon® with Intel EM64T support with SSE2 technology
- Intel Pentium 4 with Intel EM64T support with SSE2 technology

Memory

Minimum: 4 GB of RAM

Recommended: 8 GB of RAM

Graphics hardware

- Minimum – Display adapter capable of 1280 x 1024 at 24-bit true color
- Recommended – Display adapter capable of 1600 x 1050 at 24-bit true color

Hard disk space

- 3GB of free hard disk space (for installation)

.NET Framework

- .NET Framework Version 4.5